

Installation Manual

GEO N2-W2

Revision/Date 2/30.05 5



HELLENIC PIPEWORKS S.A.

Δρ. ΙΩΑΝΝΗΣ Α. ΓΕΩΡΓΙΟΥ
ΔΙΠΛΩΜ. ΜΗΧΑΝΟΛΟΓΟΣ ΜΗΧΑΝΙΚΟΣ
ΔΙΔΑΚΤΩΡ ΠΑΝΕΠΙΣΤΗΜΙΟΥ ΛΟΝΔΙΝΟΥ (IMPERIAL COLLEGE)
ΜΕΛΟΣ Τ.Ε.Ε. ΑΡΙΘΜΟΣ ΜΗΤΡΟΥΥ 92232
ΑΛΕΞ. ΠΑΠΑΓΟΥ 35 / Τ.Κ. 563 34 ΘΕΣΣΑΛΟΝΙΚΗ
Τηλ: 2310 768660 - Κωφ: 6972 622250
Α.Φ.Μ. 065673636 Α.Ο.Υ. ΓΟΝΙΑΣ

● VEHICLE RESTRAINTS ● METAL CONSTRUCTIONS

Content

1 General Information	1
1.1 Preliminary Notes	1
1.2 Manufacturer	1
1.3 Intended Use	1
1.4 Storage and Transport	2
2 Technical Data	2
3 Installation Guidelines	2
3.1 General Remarks	2
3.1.1 Place of installation	2
3.1.2 Limits of installation	3
3.1.3 Grounding	3
3.1.3.1 Soil class 1 and 2 in accordance with EN 50530	3
3.1.3.2 Soil class 3 to 5 in accordance with EN 50530	3
3.1.3.3 Soil class 6 and 7 in accordance with EN 50530	4
3.1.4 Minimum length of assembly	4
3.1.5 Permissible assembly temperatures	4
3.1.6 Requirements of installation	4
3.1.7 Control of the assembly/Labeling	4
3.1.8 Cable clarification	5
3.1.9 Traffic Safety	5
3.1.10 Personal protective gear or equipment	5
3.2 Installation	5
3.2.1 Installation height	5
3.2.2 Posts	6
3.2.3 Fittings	7
3.2.3.1 Bolts M16x40	7
3.2.3.2 Bolts M16x30	7
3.2.4 Beams	7
3.2.5 Additional attachments	7
3.3 Control, Self-Monitoring Repairs, Installation Tolerances	8
3.4 Repairs, Inspection and Maintenance	8
3.5 Disposal	9
3.6 Data For Toxic Substances	9
3.7 Miscellaneous Information	9

APPENDICES:

Appendix 1.....Parts List – per 4m section
Appendix 2.....System Drawing/ Assembly Drawing GEO N2-W2-A

COPY

1 General Information

1.1 Preliminary Notes

The Vehicle Restraint System (VRS) GEO N2-W2-A is a protective device for application at the roadside and mainly consists of the following elements:

1. Guard rail beam profile A
2. Vertical C-Post piled into the ground
3. Connecting material (bolts, nuts and washers listed in appendix)

The performance of VRS in use is strictly dependent on the correct assembly and installation phase. The current manual is intended to give all relevant requirements that have to be fulfilled during assembly and installation phase, in order for the system to meet the declared performance achieved in the Initial Test (ITT).

Proper installation is a prerequisite for the normal functioning of VRS in location and any deviation from the manufacturer's procedures, without the written agreement of the first one, will have as a result all liabilities of the affected structural products to pass from the manufacturer to the installation contractor.

When the installation is taking place in Greece, it is dependent upon the outside temperature at the time of installation (except in the case of repairs). In regions where the minimum outdoor temperature according to EN 1991-1-5/NA is below -24°C , the installation may only take place with the written approval of the manufacturer.

1.2 Manufacturer

HELLENIC PIPEWORKS S.A. (GEO-SOL S.A.)
Vehicle Restraint Systems Engineering – Metal Construction
67th km Athens-Lamia N.R.
P.O. Box 39, P.C. 22009, Schimatari
Telephone: +30 22910 59388
Fax: +30 22910 58470

1.3 Intended Use

The GEO N2-W2-A is a VRS for installation on roads. Its purpose is to minimize the effects of road accidents. It is used to protect:

- innocent bystanders and valuable property along the roadway, oncoming traffic on bi-directional roads or following vehicles,
- road users from excessive consequences due to their own errors e.g. veering off the road or impacting other vehicles or hazards along the verge.

1.4 Storage and Transport

All guard rail construction parts are to be stored and handled in a technically correct manner. They are to be protected from dirt, corrosion and damage. Construction parts laid out for fitting are to be fitted quickly. To optimize safety barrier installation and avoid obstructions on site, only the barrier material required on the day should be delivered.

When shipping, the cargo must be securely fastened so that it does not shift. The personnel doing the shipping should be outfitted with personal protective equipment according to national regulations.

2 Technical Data

Containment level according to DIN EN 1317-2	EN12
Working Width Class (scope, Reach)	0.8 m)
Minimum length	34 m
ASI value	A
Height of construction (measured from top edge of hard surface)	3 cm tolerance
Driving depth	Approx. 10 mm
Width of construction	205 mm
Distance between posts	200 cm
Weight per meter	17,85 kg/m
Material	S235JR – EN 10025/EN 1461
Galvanizing of the steel bolts	In accordance with EN ISO 1461 or EN 10346
Expected durability	Approx. 20 years shorter in the case of more severe atmospheric corrosion exposure

3 Installation Guidelines

3.1 General Remarks

3.1.1 Place of installation

The installation of steel safety barrier depends on the road type, the type of hazard and the design speed. In choosing the place of installation, the respective national regulations and the system performance, obtained from crash tests carried out according to EN1317-2, are to be considered.

As a basic principle for choosing the place of installation it can be considered the distance behind the safety device always to be in accordance with the working width of the system obtained during the ITT.

The current system involves a pile-driven guard rail system, which has proved the following performance in the crash test according to EN 1317-2:

- N2-W2-A

3.1.2 Limits of installation

The general limits of installation for GEO N2-W2-A have not been specified because the local conditions are so varying. Should the basic construction for any reason be deviated from because of the installation site, then the requirements should be agreed in place in agreement with the contractee and the manufacturer.

In the execution of the installation the general rules of engineering are to be observed and adhered to.

3.1.3 Grounding

The area in front of and below the VR should be sufficiently load bearing (for a car). With regards to piling posts, the ground should be divided into the following ground types (according to DIN 18300):

- Ground type 1-2 – Top soil or quick soil types
- Ground type 3-5 – Soil that is difficult with little, average or much difficulty
- Ground type 6 – Rocky soil with difficulty and similar types
- Ground type 7 – Soil that loosens with difficulty

3.1.3.1 Soil class 1 and 2 in accordance with DIN 18300

GEO N2-W2-A is not suitable for this ground class and should not be installed under these conditions. An alternative would be to change the ground with suitable material or the construction of strip foundation.

3.1.3.2 Soil class 3 to 5 in accordance with DIN 18300

GEO N2-W2-A is suitable for this ground class and may be installed if the pile-driving time for each post does not exceed 4 minutes and no deformation or damage to the heads of the posts occurs. as happens in the case of a ground with stones of sizes $> 0.1 \text{ m}^3$, so that a flawless installation and functioning of the system is guaranteed. Damages to the hot dip galvanized sheet piling should be repaired in a technically correct manner. In the case that the posts are deformed or moved from their correct position while pile-driving then proceed as follows.

3.1.3.3 Soil class 6 and 7 in accordance with DIN 18300

GEO N2-W2-A is not suitable for this ground class and should not be installed under these conditions. In these cases an alternative installation method based on drilling procedures, needs to be followed that is not part of the current manual.

3.1.4 Minimum length of assembly

The minimum construction length of GEO N2-W2-A VRS should be less than 84 m. In the case that the required tested length of the construction cannot be met, the performance characteristics of the VRS cannot be met and the manufacturer should be consulted for a special onetime construction.

3.1.5 Permissible assembly temperatures

In the case that the assembly takes place in winter, it is independent of the surrounding temperature at the time of assembly. In regions where the minimum outside temperature according to EN 1991-1-5 is below -24°C , an assembly is only to take place with the written consent of the manufacturer.

3.1.6 Requirements for installation personnel

Due to product liability, VRS installations should only be carried out by competent companies with trained personnel. The installation crew usually consists of 3 to 5 workers (depending on construction type). The installation crew consists of a foreman working the rammer and assembly workers. The foreman is trained for Safety and First Aid in case of accidents and Environmental Safety. The installation work is managed by trained supervisors with appropriate experience.

The crew distributes the safety barrier parts along the installation section and assembles the safety barrier beams according to the manufacturer's drawings. The crew writes daily reports on completed work and documents progress.

The personnel should be equipped with their own personal protective gear according to the National Occupational and Safety Rules.

3.1.7 Content of the delivery – Labeling of the parts

The delivered VRS components are to be compared with the delivery note, examined for completeness and damaged at the construction site. Also the part lists in Appendix 1 are to be consulted.

Faults, damages or wrong deliveries are to be reported immediately to the manufacturer. Packaging material is to be disposed of according to the local rules and regulations. The

contractor is responsible for material disposition and installation and therefore responsible for daily delivery and work assignment.

3.1.8 Cable clarification

Prior to commencing work, the contractor must check the position and direction of cables, pipes, ducts etc. Posts should not be driven in areas with underground lines. The instructions of the owner of the cables, pipes and ducts are to be followed.

3.1.9 Traffic safety

If there is live traffic on the road, the sections of safety barrier installed should be designed on the same day and fully bolted.

The construction zones are to be secured according to the national requirements.

3.1.10 Personal protective gear or equipment

Protective gear must be worn at all times by the personnel according to the national rules and regulations.

3.2 Installation

The installation of GEO N2-W2-A system is to be carried out according to the drawings given in Appendix 2. General information on the assembly process of the system is given in Appendix 2.

During assembly of the system, attention must be paid to avoid any damage of the galvanized surfaces. When setting the posts always use a post protection attachment. Directly hammering of the galvanized surfaces is not permitted.

Small defects on the galvanization must be renovated after careful preparation by suitable zinc-rich paint or dust coating according to EN ISO 1461.

In any work involved with the guard rail construction (new, repair, maintenance) will only be used new galvanized material.

3.2.1 Installation height

The standard installation height of GEO N2-W2-A is 75 ± 3 cm over the road surface (see Figure 1). The distance from the front edge of GEO N2-W2-A from the edge of the stabilized surface should normally be 50 cm.

Figure 1: Installation height of GEO N2-W2-A

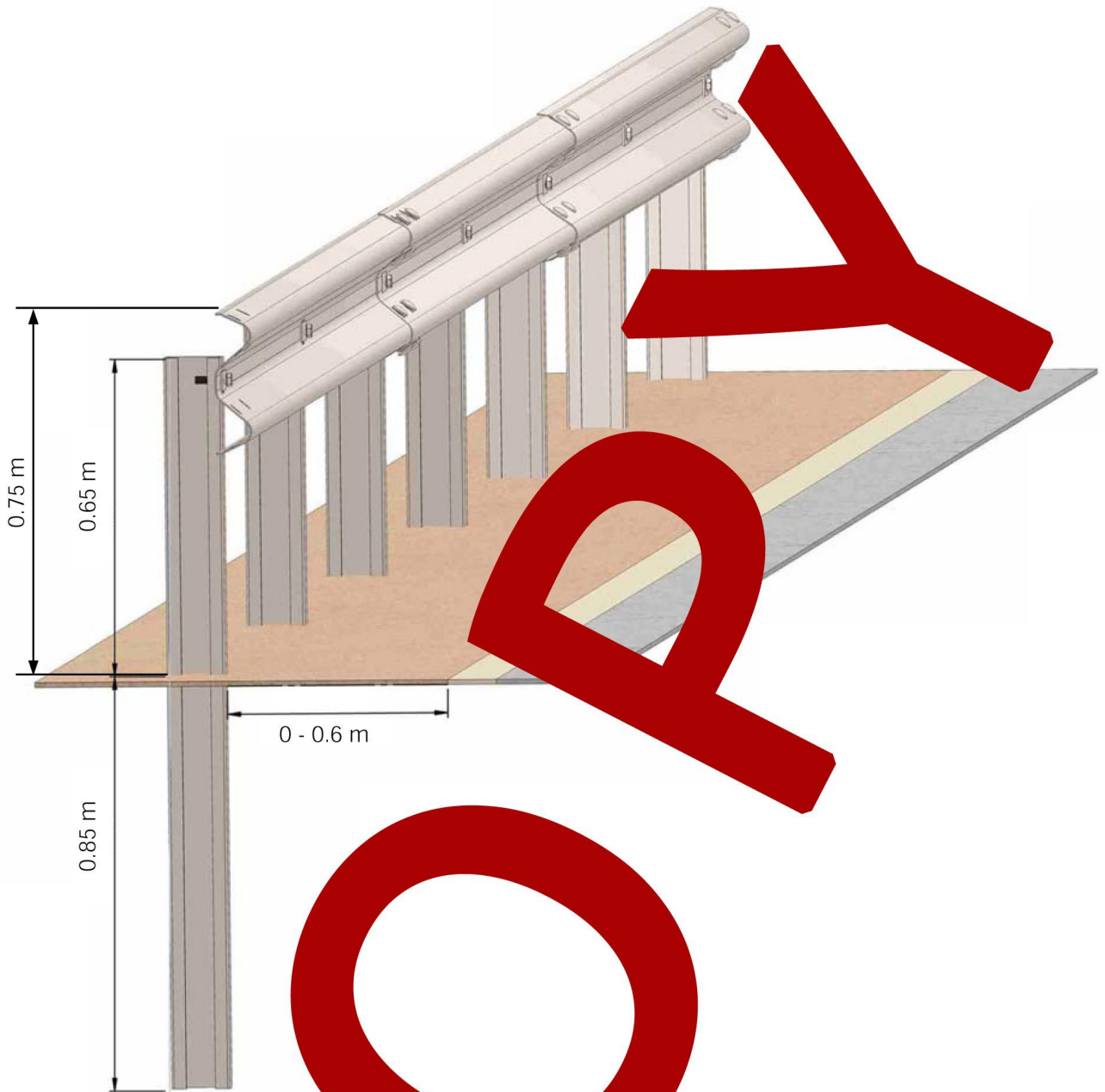

3.2.2 Posts

Posts of GEO N2-W2-A system are piled into the ground with a pneumatic or hydraulic pile driver and a special piling piece for C-posts. A pneumatic pile hammer should have a single hit energy per bar of at least 420 Nm. For hydraulic pile hammers a pressure of at least 70 bar is recommended.

The assembly of posts is to take place on the closed side of the road against the traffic. The designated distance between posts may not be exceeded. In the case that a post cannot be set at the designated place because of adverse conditions at the construction site (cables, shafts, tunnels, tree roots, etc.) then it is to be set in the shortest

possible distance from the designated position and an additional post is to be placed in the next "field".

Increasing the post spacing is not permitted. If this is the case, a special agreement must be made with the contractee with regards to special measures such as single dug posts or foundations. In all cases the written consent of the manufacturer is required.

3.2.3 Fittings

For a proper connection to be achieved, the screws and nuts in the connecting construction parts and are to be tightened according to regulations. The drilling tools need to be adjusted accordingly. When tightening the nuts a washer should be placed under each nut in order that the zinc surface is not damaged. A butt plate is not to be used as a replacement for a washer.

Generally only hot dip galvanized bolts may be used. Material class 4.6 may not be deviated from upwards or downwards.

Bolt connection material that has been fitted once is not to be re-used.

3.2.3.1 Bolts M16x40, 8.8

The bolts 16x40 M between the posts and posts are to be bolted together and hand-tightened. (Minimum torque applied should be at least 50 Nm).

3.2.3.2 Bolts M16x30

The bolts 16x30 M for connecting end to end are to be bolted together with a torque of at least 90 Nm. For the joint-bolting take heed that the nose of the roundhead bolt is placed in the forefront of the long hole.

The required tools for bolting are suitable socket wrenches or screw wrenches.

3.2.4 Bolting

Overlap of safety barrier beams at the joints should be in the traffic direction.

3.2.5 Additional Attachments

The following complete attachments may be mounted to the GEO N2-W2-A system:

- Attached guide posts, which can be mounted on posts.
- Attached guide posts, which can be mounted together with the joint-bolting on the beam.

- Traffic signs, as long as no dangers come about because of them.
- Guard rail reflectors, which are attached to the beam with HRK bolts at the middle punched hole.
- Guard rail post sheathings

For the mounting of additional attachments (e.g. anti-glare screens under ride protection, etc.) a written consent of the manufacturer is required.

The attaching of traffic signs is not permitted. Traffic signs in the area of work, as long as on impact they bend over or break off.

3.3 Controls, Self-Monitoring Reports, Installation Tolerances

After installation the construction is to be checked with regard to the general known rules of engineering. Adherence to staying within the tolerances of installation should be particularly taken into account.

Compliance to installation tolerances, the fixing of the bolts and the technically correct alignment of the stretches of guard rails are particularly to be heeded.

The installation tolerances are:

Measurement	Tolerance
Spacing of the posts lengthwise	+21 mm
Deviation of alignment of posts or beams	in length of 12 m: +30 mm
Deviation of top edge of beam vertically	+ 30mm

3.4 Repair, Inspection and Maintenance

Generally all guard rail parts with permanent (plastic) deformation are to be replaced. If permanent (plastic) deformation exists, then the VRS does not provide any further safety. If construction parts in a guard rail section, which has come out of line up to approximately 30 cm, are not deformed permanently, then the guard rail construction must be adjusted.

In doing so, corresponding and embedded postholes are to be filled and sufficiently packed. When damaged parts are replaced, special care must be taken when working in areas connected to damaged beams. The beams that remain after removal of the damaged parts may not be damaged (e.g. through the use of an angle grinder, mandrel or a hammer).

Due to temperature related length differences or due to the bending process with severe crashes, the hole patterns in longitudinal direction often do no longer match the remaining beams. In the case that the distance between hole axes is less than 5 cm, often the difference can be compensated for by loosening several sets of bolts.

Widened post holes in the embankment must be compacted again so that the newly piled in post is sufficiently stable. After several collision damages at the same place, compacting the entire embankment or fitting of additional posts may become necessary. This should be done in consultation with the contracting authority.

3.5 Disposal – Recycling

Damaged building parts and building parts that are no longer to be used, are to be subjected completely to utilization/recycling or be installed for other purposes (for example: farming, solar standing supports, private business).

3.6 Data For Toxic Substances

The VRS components consist of two main building materials:

- steel
- zinc (hot dip galvanizing)

Both components are not toxic and do not need of any special treatment or operation.

For on-site installation of heavy substances are required for the operation of machines and tools. For example these could be:

- diesel (e.g. compressor)
- pneumatic oil (e.g. operation of air pressure tools)
- gasoline (e.g. cutting machine)
- grease or cutting paste (e.g. for holes in guard rail parts)

In these cases the relevant data from the manufacturer should be considered and the requirements of the individual countries should be met.

3.7 Miscellaneous Information

Since the height of the GEO N2 is relatively low, i.e. 75 cm, it can be stepped over without the need for any additional structure.

Appendix 1

Parts List – per 4m section

GEO N2-W2-A, driven posts:

Pcs./4m	Designation	Weight per pc	Total
1	Beam, L = 4316 mm, t = 2,5 mm	39,50 kg	39,50 Kg
2	Post, L = 1500 mm, t = 5,0 mm	30,30 kg	60,60 Kg
2	Cover Plate, t = 4,0 mm	0,11 kg	0,22 kg
8	Bolt M16x30, 8.8, incl. nut; DIN 607	0,097 kg	0,77 kg
2	Bolt M16x40, 8.8, incl. nut; DIN 607	0,115 kg	0,23 kg
10	Washer Ø17, DIN 125	0,01 kg	0,10 kg
Construction weight per 4m section:			71,40 kg
Construction weight per 1m section:			17,85 kg

Appendix 2

System Drawing/Assembly Drawing GEO N2-W2-A

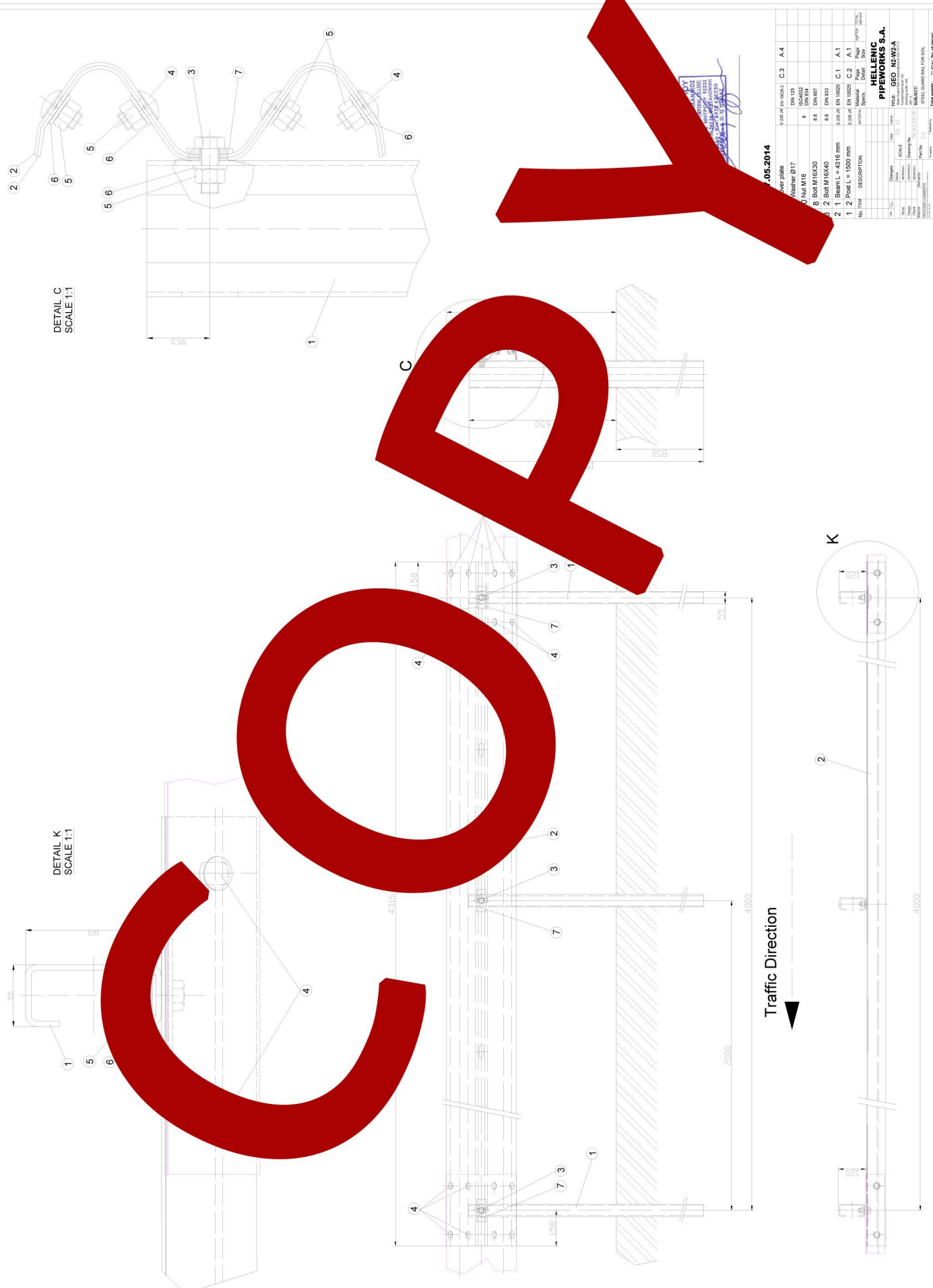

05.2014

Revizija	EN 10025-2	C3	A.4
Washer Ø17	EN 10204		
Nut M16	EN 10204		
Bolt M16x30	EN 10204		
Beam L = 4316 mm	EN 10025-2	C.1	A.1
Post L = 1500 mm	EN 10025-2	C.2	A.1

HELLENIC PIPEWORKS S.A.

11

GEO N2-W2-A Plate

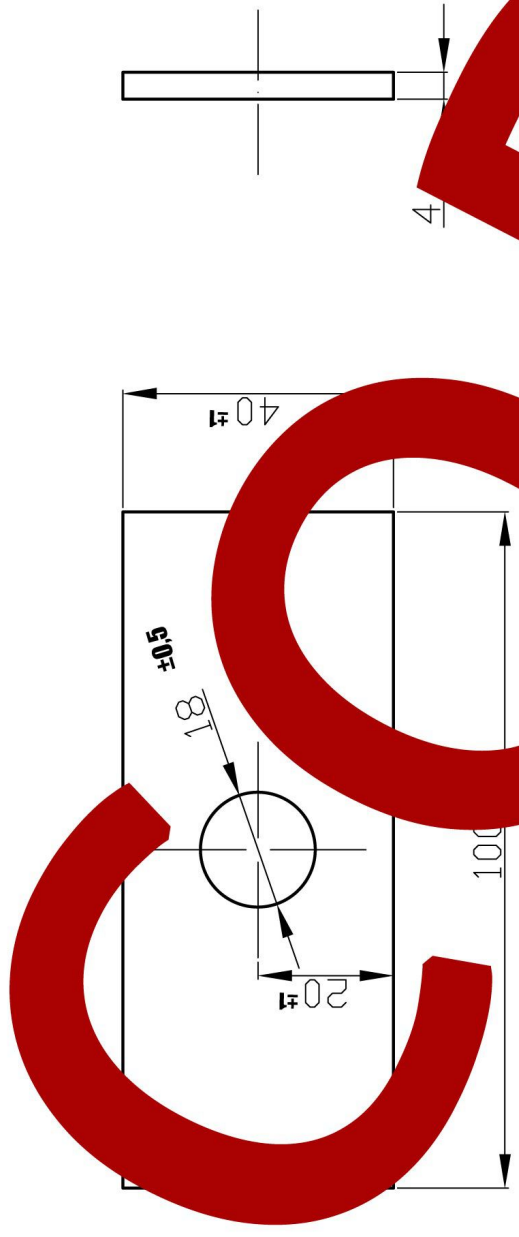

Δ. ΓΕΩΡΓΙΟΥ
 ΔΙΑΧΕΙΡΙΣΤΗΣ ΜΕΛΕΤΩΝ (IMPERIAL COLLEGE)
 Ε.Ε. ΑΠΟΜΑΧΩΝ ΤΡΟΧΟΣ 92232
 ΑΝΤΙΣΤΡΩΦΕΥΣΕΩΝ ΣΤΑΘΜΩΝ
 ΑΣΙ 35/ Τ. 972 692250
 ΑΤΟΜΟΦΩΝΟ Τ. 972 692250
 Μ. 0655656565
 Υ. ΙΩΝΙΑΣ

DATE: 17.05.2014

Line		No. of changes		Changes		Date		Name	
Study		Date		Name		SCALE		1:1	
Design		GEORGIOU I.		SGOURDAS C.		Drawing No.		N2.W2.100.03	
Check		GEORGIOU I.		Material: S 235 JR		Standard: EN 10025-2		Part No. C.3	
PROCESS COMMENTS All parts must be hot dip galvanized in accordance to ISO EN DIN1461									
Title: GEO N2-A Steel Guard Rail in accordance to EN 1317-2 Containment level: N2 Working width: W2 ASI: A					SUBJECT: COVER PLATE				
HELIX S.A.					Total weight: 0.11 kg/item Total items: 2				

GEO N2-W2-A Mechanical Fasteners

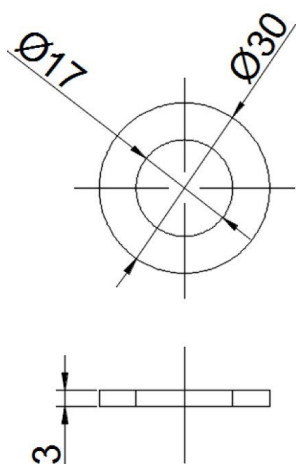

Washer $\varnothing 17$ – DIN125

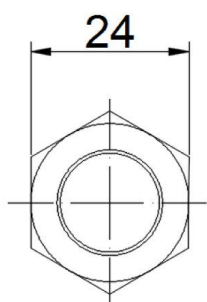
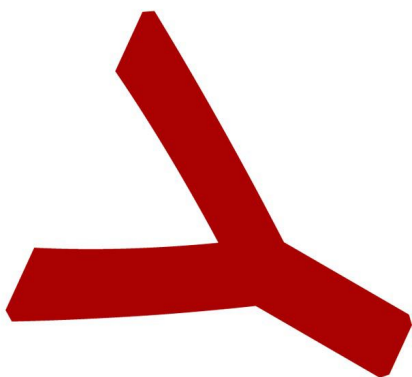

Nut M16 – ISO4032 – DIN934

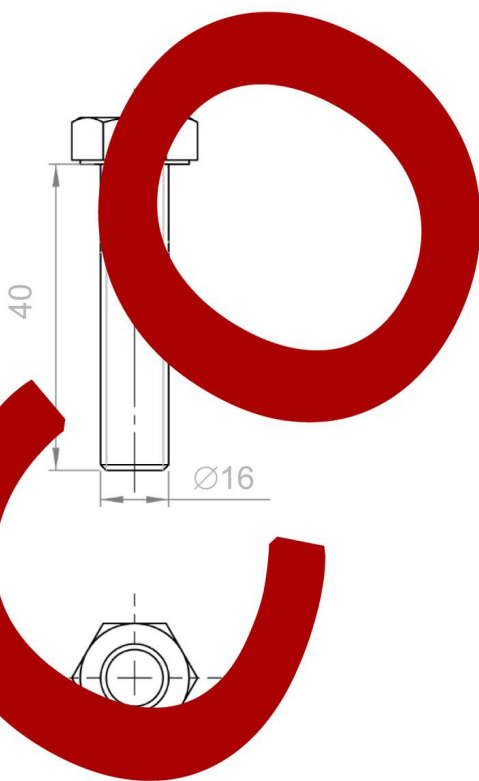

Bolt M16x40 DIN933

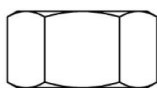
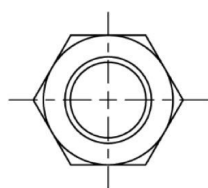

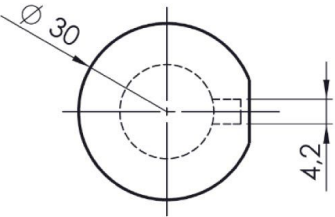
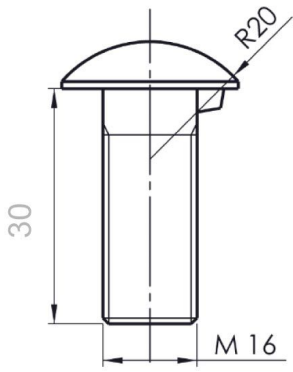

Bolt M16x30 DIN607

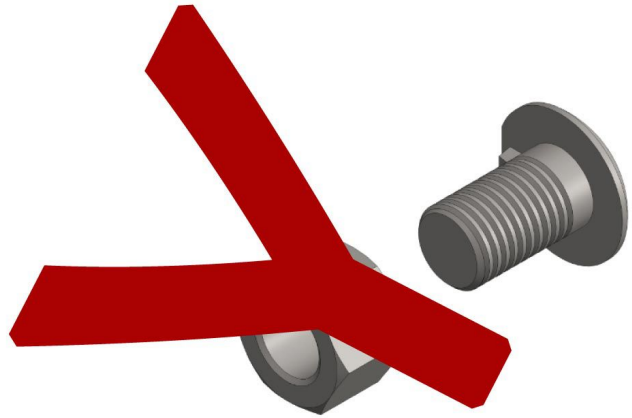
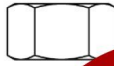
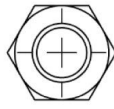

COR